



OVR10 - the power controller for IR oven on PET Blowing machines

TECHNICAL MANUAL V 1.1



TECHNOPLAN
ENGINEERING SA

Technoplan Engineering SA
Chemin des Aulx 16
1228, Plan-les-Ouates, GE
Switzerland
email : info@technoplan.info
phone : +41 (0)22 794 0084

Safety and security aspects

Symbols



This symbol means that failure to take note of the information given in this manual may have serious consequences for the safety of the personnel or may result in electrocution.



This symbol means that failure to take note of the information given in this manual may have serious consequences for the installation, lead to incorrect operation of the product, or may damage the product.

Safety



The installation, configuration, commissioning and maintenance of the OVR10 products must only be carried out by personnel qualified and trained to work with low voltage electrical equipment in an industrial environment.



The front door should not be opened except by competent technicians when connecting or disconnecting the device. Electrical isolation must be ensured between the equipment and the power supply.



In both off and on modes, the OVR10 regulator doesn't ensure isolation from the power supply. One should pay attention to the fact that electrical shock may occur when touching the lamps or the cables coming from the OVR10. It is thus recommended to turn off the main power supply of the machine within 2 seconds following the end of regulation.

Table of content

Introduction	4
Description	5
2.1 Area of application	5
2.2 Global feature	5
2.3 Technical data	6
Mounting	8
3.1 Mounting the Device	8
3.2 Dimensions drawing	9
Connections	10
4.1 Connection element locations	10
4.2 X1 (mains connection / grounding)	11
4.3 X2 (heating element connection)	12
4.4 X3 (PROFIBUS DP / 24 VDC)	12
4.5 X4 (PROFIBUS DP / 24 VDC)	13
Commissioning	14
5.1 Hardware requirements and commissioning Steps	14
5.2 Firmware version	14
5.3 Integrating the GSD file	16
5.4 Setting the bus address	24
5.5 Profibus DP Bus terminator.	27
Maintenance	28
6.1 Fuses replacement	28

Introduction

Purpose of this documentation

These operating instructions contain all the information you require to commission and operate the OVR10 heating controller.

Target group

The documentation is intended for qualified personnel in the following specialist fields:

- Operators, project engineers, programmers
- Electrically skilled personnel, who assemble, connect and start up the device.

Required basic knowledge

- These operating instructions require prior knowledge of programming a PLC controller as Master PROFIBUS DP.
- Knowledge of working with the PROFIBUS DP fieldbus is also necessary.

History

The following earlier release versions of these operating instructions have been published:
July 2017 : First edition

Registered trademarks

OVR10[®] is a registered trademark of Technoplan Engineering SA.

Description

OVR10 - the power controller for IR oven on PET Blowing machines.

2.1 Area of application

The compact OVR10 with high IP65 protection rating can be used nearby each oven of the machine for easier integration and perfect control of the Heating process.

2.2 Global feature

The power controller OVR10 is directly connected with Harting Plugs to an oven unit and to the AC power supply of the Blowing machine.

OVR10 is a Profibus DP slave and connected to the 24VDC supply.

The OVR10 aims to control up to 10 Infrared lamps into an oven unit.

The OVR10 system is a complete power cabinet by itself. It includes the regulation controller, the power electronics thyristors, and an integrated overload protection, all integrated in an IP65 cabinet. This concept makes it easy to connect and to mount. Maintenance is also greatly facilitated by suppressing complex electrical cabinets by small plug and play single units.

The OVR10 operates 2 Firmwares :

- The version 5.x used on standard blow molding machines.
- The version 20.x used on Sidel® machines.

2.3 Technical data

	Firmware Version 5.x	Firmware Version 20.x
VAC Power supply	207 to 440 VAC - 47 to 63 HZ	400 VAC +/- 10% 47 to 63 HZ
Power supply current	Maximum 65A	Idem
Power outputs	x10 with maximum 7.5A RMS current	Idem
Type of Load	Ohmic Load	Idem
Number of load per output	1	Idem
Short-circuit protection per output	X2 fuses 10x38 type gG 25A	Idem
Type of modulation on outputs	Zero-crossing or Half-angle	Zero-crossing
Accuracy of the regulation on each outputs	For the power applied : +/- 1%	For the voltage applied : +/- 1%
24VDC supply	24VDC +/-10% - 250 mA	idem
Profibus DP (Slave)	Up to 12 Mbaup	Idem
Serial interface	RS232	Idem

Electromagnetic compatibility EMC emitted interference	Limit value class A in accordance with EN 61000-6-4:2007 + A1:2011 Group 1
Electrostatic discharge according to IEC 61000-4-2	4 kV contact discharge / 8 kV air discharge
Field-bound parasitic coupling according to IEC 61000-4-3	10 V/m (80 MHz ... 1000 MHz), 3 V/m (1,4 GHz ... 2.0 GHz), 1 V/m (2.0 GHz ... 2.7 GHz)
Conductor-bound parasitic coupling BURST according to IEC 61000-4-4	2 kV power supply lines / 1 kV signal lines
Conductor-bound parasitic coupling SURGE according to IEC 61000-4-5	On supply lines: 1 kV symmetrical, 2 kV asymmetrical, (24 V DC supply only with external protective measure) PROFIBUS cable asymmetrical 1 kV
Conducted interference as high-frequency radiation according to IEC 61000-4-6	10 V (0.15 ... 80 MHz)
Overvoltage class	Installation category III

Climatic environmental conditions (ambient temperature)		
During transport	°C	-40 ... +70
During storage	°C	-40 ... +70
During operating	°C	0 ... 50
Installation altitude at a height over sea level maximum	m	2000
Air pressure		
During storage	hPa	660 ... 1080
During operating phase	hPa	860 ... 1080
Relative humidity at 25 °C during operating maximum	%	95
Relative humidity at 50 °C during operating maximum	%	50
		Linear decreasing to 50 %

Mechanical features mounting position		Vertical
Type of mounting		Screw fixing + silent bloc
Nature of the ventilation		Self-ventilation
Resistance against shock according to IEC 60068-2-27		15g / 11 ms / 3 shocks / axis
Vibration resistance during storage in accordance with IEC 60068-2-6		5 ... 9 Hz / 3.5 mm, 9 ... 500 Hz / 1g
Protection class IP		IP65
Depth	mm	160
Height	mm	380
Width	mm	300

CE relevant European directives

Low Voltage compliance

The OVR10 products carry the CE mark in compliance with the essential requirements of the European Low Voltage Directive 73/23/EEC of 19/2/73, amended by the directive 93/68/EEC of 22/7/93.

The OVR10 products installed and used in compliance with the procedures described in the present document meet the essential requirements of the European Low Voltage Directive.

CE Label

By fulfilling the requirements of the Low voltage and EMC regulations, the OVR10 products are compliant with the CE directives.

Profibus® standard compliance

The OVR10 carries the Profibus-DP compliance label.

Mounting

3.1 Mounting the Device

The OVR10 with high IP65 protection rating can be mounted vertical on the frame of the machine and nearby each oven.

Natural convection must be possible above and below the device. A clearance of 150 mm must be observed around the OVR10.

See an installation video of the OVR10 : <http://www.technoplan.info/fr/ovr10-en/>



3.2 Dimensions drawing

*On request at info@technoplan.com 3D files Step or IGES format.

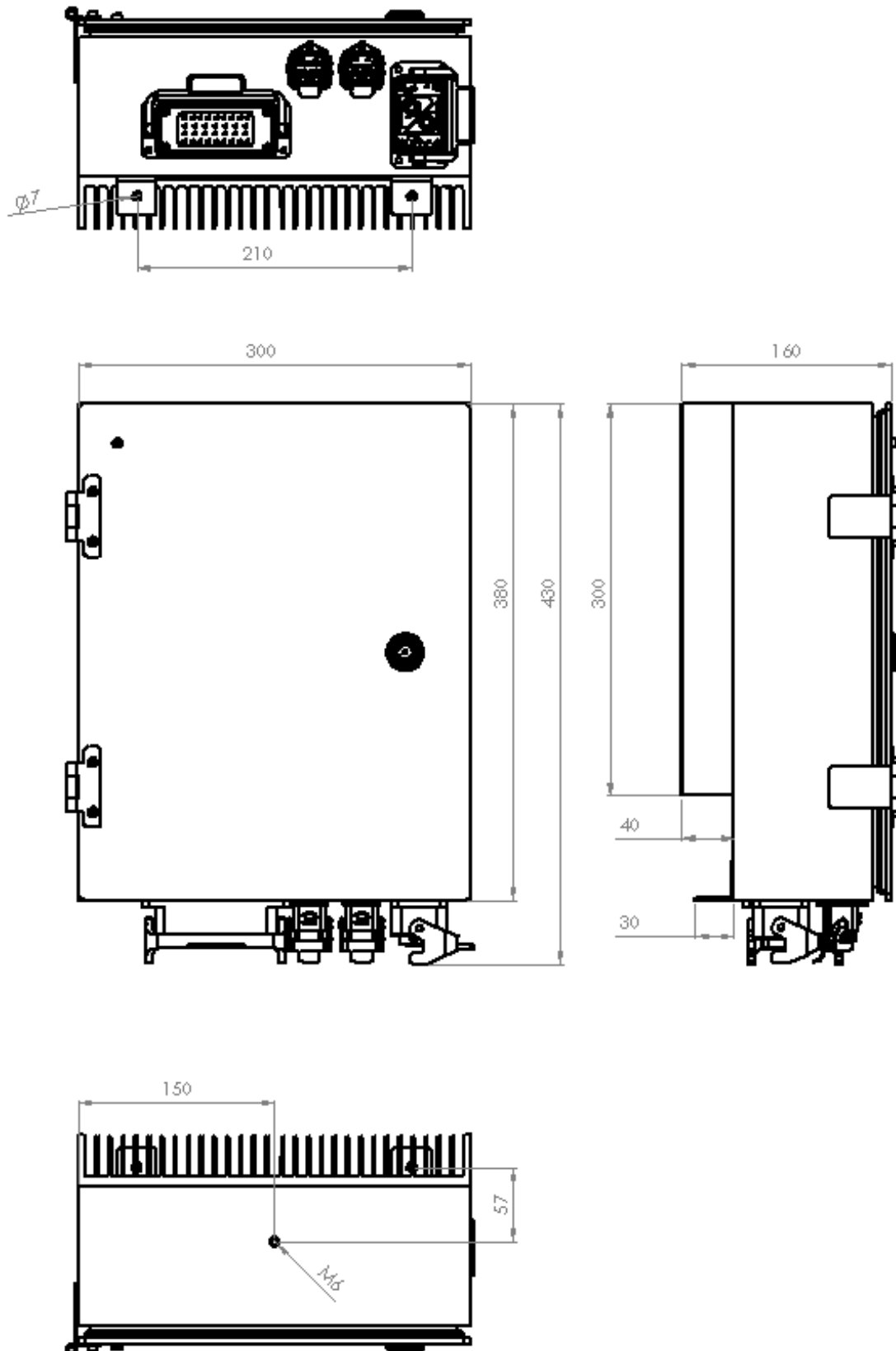

Connections

4.1 Connection element locations

The position of the connection elements of the OVR10 on the underside of the device is shown in the figure below.

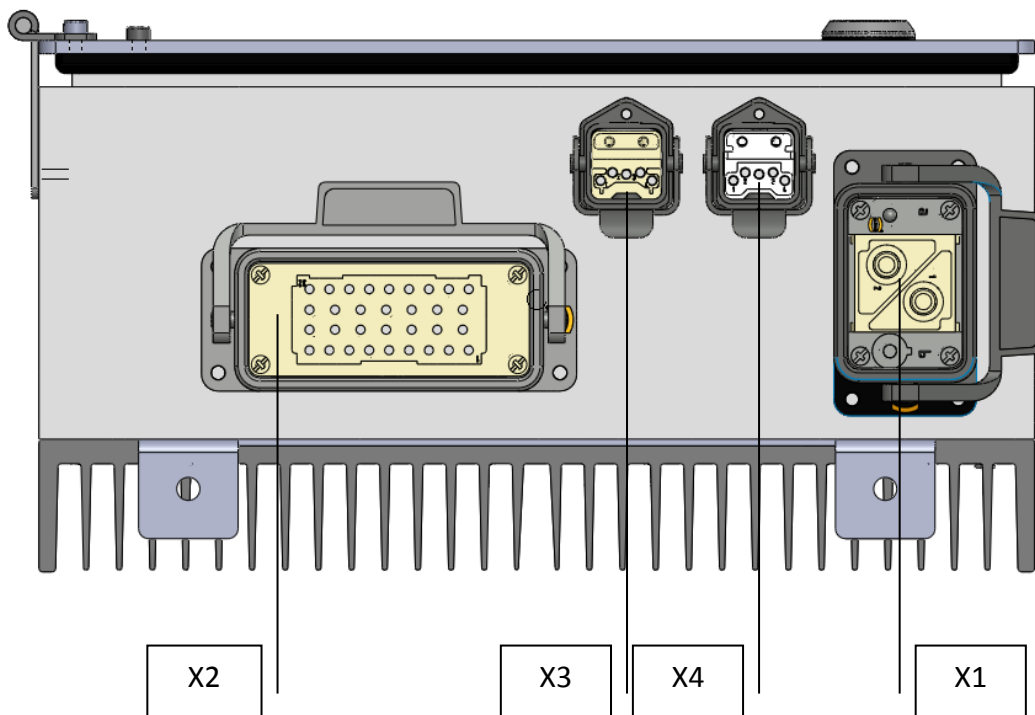

- | | |
|----|------------------------------------|
| X1 | Main connection |
| X2 | Heating elements |
| X3 | Profibus DP / 24VDC supply voltage |
| X4 | Profibus DP / 24VDC supply voltage |

4.2 X1 (mains connection / grounding)

Socket X1 is used to connect the mains supply.
Harting connector on the OVR10 :

Insert male	Harting	09 14 002 2651
Cable shoe	Harting	09 14 000 9912
modules a..b	Harting	09 14 006 0313
Socket	Harting	09 30 006 0301

X1 pin assignment :

Pin	Assignment
1	Phase 1
2	Phase 2
a / b	GND



4.3 X2 (heating element connection)

Socket X2 is used to connect the oven unit equipped with 10 heating elements.
Harting connector on the OVR10 :

Socket 16B	Harting	09 30 016 0307
Insert female Han 32EE	Harting	09 32 032 3101
Contact female S=1.5/AWG 16	Harting	09 33 000 6204

X2 pin assignment :

Heating element	1	2	3	4	5	6	7	8	9	10
Pin	1	2	3	4	5	6	7	8	9	10
Pin	24	25	26	27	28	29	30	31	32	17

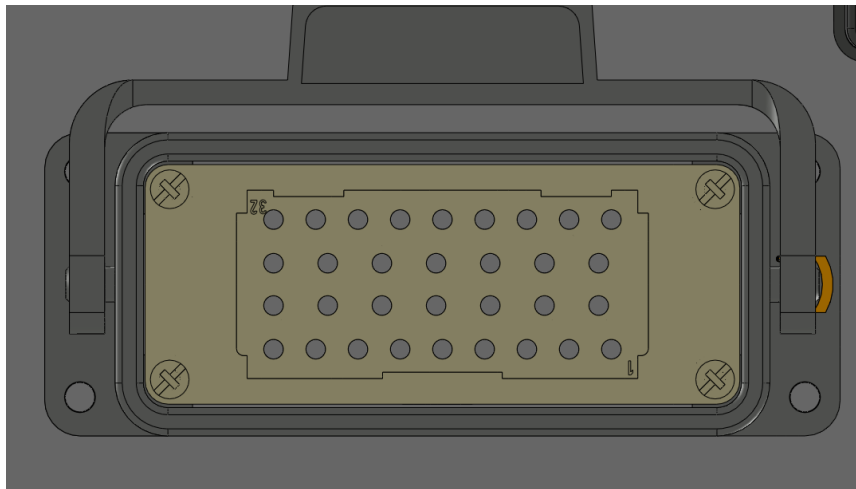

4.4 X3 (PROFIBUS DP / 24 VDC)

Socket X3 is used to connect Profibus DP and the 24VDC.
Harting connector on the OVR10 :

Socket 3A	Harting	09 20 003 0327
Insert female	Harting	09 12 006 2794
Contact	Harting	09 15 000 6206
Contact	Harting	09 15 000 6106

4.5 X4 (PROFIBUS DP / 24 VDC)

Socket X4 is used to connect Profibus DP and the 24VDC.

Harting connector on the OVR10 :

Socket 3A	Harting	09 20 003 0327
Insert male	Harting	09 12 006 2694
Contact	Harting	09 15 000 6123
Contact	Harting	09 15 000 6223

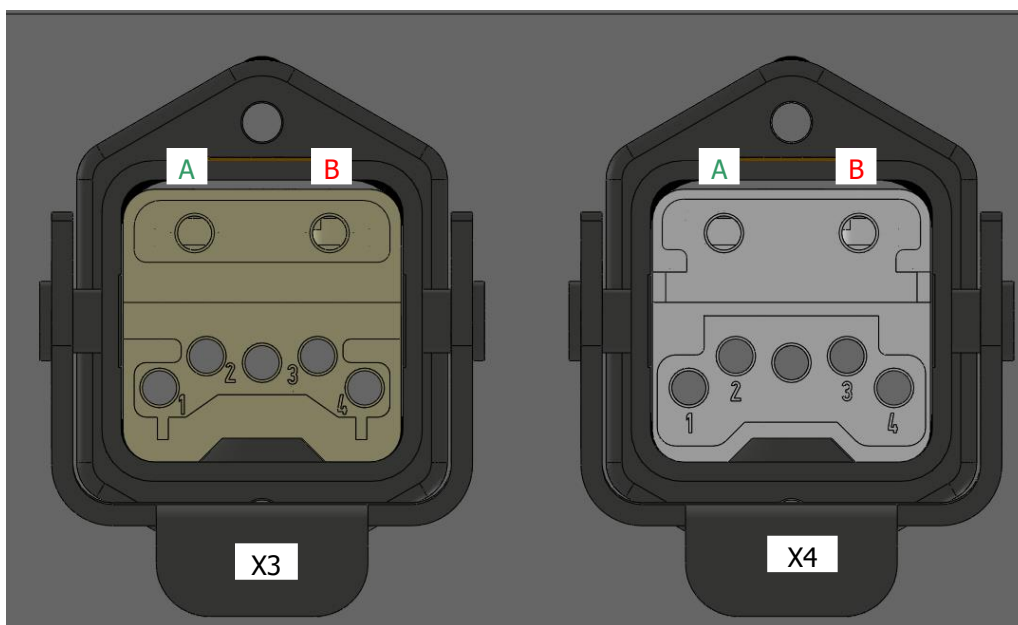

Pins	X3	X4
1	+24VDC	+24VDC
2	0VDC	0VDC
3	Connected Pin 3 X4	Connected Pin 3 X3
4	Connected Pin 4 X4	Connected Pin 4 X3
A B	Profibus DP	Profibus DP

Commissioning

5.1 Hardware requirements and commissioning Steps

Requirements for commissioning

Before commissioning starts, the system components must be installed and wired up on the machine.

The following is necessary:

- PLC or System master with PROFIBUS DP interface
- PROFIBUS DP + 24VDC
- Main VAC Power supply
- OVR10 heating controller(s)
- Oven unit with up to 10 Lamps

5.2 Firmware version

Automation strategy for 20.X Firmware (Sidel®). Voltage regulation mode.

The automation strategy describes the different possible solutions to control the power system with the PLC:

- Starting the regulation (oven on/off)
- Sending the power settings for the oven
- Treating the data from the OVR10 (alarms).

Starting the regulation

To start the regulation, the PLC has to send:

- The desired power (% of nominal power) applied for each lamp
- The start/stop command

Treating the information back from the OVR10

The PLC has to treat the information coming back from the OVR10:

- The supply Voltage: SV (Volts)
- The alarms:
 - ✓ Overload
 - ✓ Cutout
 - ✓ Overheat

- ✓ Sector default
- ✓ Lamps states (Broken or not) for the ones that are ON.

Stopping the regulation

To stop the regulation, the PLC has to send:

- The start/stop command

System Shutdown

The main supply must be switched off first. Otherwise, this step doesn't require any specific action.

Automation strategy for 5.X Firmware – Power regulation mode.

The automation strategy describes the different possible solutions to control the power system with the PLC :

- Starting the regulation (oven on/off)
- Sending the power settings for the each lamps (Watt)
- Treating the data from the OVR10 (alarms, measured resistance)

System configuration

Before doing anything with the OVR10 regulator, it will be necessary to configure the basic functions of the device :

- Regulation mode : Phase angle, advanced singlecycle
- Set delay and power for the warmup of the lamps
- Turning on or off the resistance measurement

Optional : Preset the regulation parameters (lamps service voltage, lamps nominal power)

System initialisation at start-up

If not done during initial system configuration, at system start-up the basic parameters used by the regulator must be sent by the PLC (or PC) to the OVR10 for each lamp.

These parameters are :

- the lamps service voltage : SRVV (Volts)
- the lamps nominal power : MaxPower (Watt)

This step can be avoided, if one stores these values directly on the control board. The SUPERVISOR software, used to configure the settings of the OVR10, has an option to set SRVV and MaxP in the ROM memory of the OVR10.

If this option is used, it is even possible to select a simplified Profibus DP protocole (*OVR_STD_SHORT* instead of *OVR_STD*) to ease the programming of the PLC by suppressing the parameters *SRVV* and *MaxP* in the Profibus Protocole.

Starting the regulation

To start the regulation, the PLC has to send :

- the desired power for each lamp : PW (Watts)
- the start/stop command

Treating the information back from the OVR10

The PLC has to treat the information coming back from the OVR10 :

- Measured resistances: RM (Ohms)
- The Applied Power: PWE (Watt)
- The supply Voltage: SV (Volts square)
- The alarms:
 - ✓ Overload
 - ✓ Overheat
 - ✓ Sector default
 - ✓ Dead lamp

System Shutdown

The main supply must be switched off first. Otherwise, this step doesn't require any specific action.

5.3 Integrating the GSD file

Profibus DP : For Firmwares 5.X

Overview

The OVR10 power regulator is a PROFIBUS-DP slave which runs accordingly to the Profibus-DP specifications defined in the standards EN50170/DIN19245/Part 3.

With Profibus DP, the MASTER DEVICES (PLC or other) control the data communication on the bus while the SLAVES DEVICES (OVR10 or other) only answer the requests from the masters.

Procedure to use a OVR10 regulator with a PLC :

Initialisation :

The GSD file provided by Technoplan contains a standardized description of the OVR10 regulator, which enables the automatic detection of the OVR10 regulator by the master.

Incorporate the different slaves in the project.

With the Siemens environment it's simply done by the OVR10 slave from the Slave list to the profibus network in the STEP7 programming interface.

According to the GSD two protocols can be selected:

- OVR_STD12
- OVR_STD12_SHORT

The slave ID is set using the ID wheels on the main MPU board. Turn off/on the 24 DC supply to reload the new address.

The master is starting to exchange empty datagrams with the OVR10 slaves. If this exchange is successful the profibus LED onto the MPU card turns to green.

Start communication by sending commands and receiving data to/from the OVR10.

Then the communication is done through simple datagram exchanges between the master and the slaves.

Protocol description and datagram format :

Configuration datagram

The configuration datagram is built according to the GSD description :

Two type of protocols are available on the OVR10 system:

- OVR_STD12
- OVR_STD12_SHORT

The SHORT version is used to simplify and optimize the exchange by suppressing the information about SRVV and Pmax (2 x 12 words are suppressed in the datagram).

To work with this version, one has to set these values manually with the OLPWR24COM software and to save them in the ROM memory of the OVR10 during system installation.

- IRS_PWR_STD12 - INPUT 5 WORDS – OUTPUT 37 WORDS

0xD4, 0xEC, 0xEB, 0xEB

0xD4 = 11010100

```

| | | | |
| | | | |
| | | | | +---+ Data Length 0100 == 5
| | | | | +-+---- Input (Slave->Master)
| | | | | +----- Type = Word
| | | | | +----- Coherent check
```

0xEC = 11101100
 |||||
 |||++++ Longueur données 1011 == 13
 |++----- Output (M->S)
 |+----- Unité = Word
 +----- Cohérence sur données complètes

0xEB = 11101011
 |||||
 |||++++- Longueur données 1011 == 12
 |++----- Output (M->S)
 |+----- Unité = Word
 +----- Cohérence sur données complètes

0xEB = 11101011
 |||||
 |||++++- Longueur données 1011 == 12
 |++----- Output (M->S)
 |+----- Unité = Word
 +----- Cohérence sur données complètes

- IRS_PWR_STD12_SHORT – INPUT 5 WORDS – OUTPUT 13 WORDS

0xD4, 0xE0, 0xEB

0xD4 = 11010100
 |||||
 |||++++- Data Length 0100 == 5
 |++----- Input (Slave->Master)
 |+----- Type = Word
 +----- Coherent check

0xE0 = 11100000
 |||||
 |||++++ Data Length 0000 == 1
 |++----- Output (M->S)
 |+----- Type = Word
 +----- Coherent check

0xEB = 11101011
 |||||
 |||++++- Data Length 1011 == 12
 |++----- Output (M->S)
 |+----- Type = Word
 +----- Coherent check

Input Datagram (S -> M) (5 words)

Command	Reserved.	P not Ok		BL		Sqr(Vrms)			
0	1	2	3	4	5	6	7	8	9

Byte 0 : Command byte content :

bit	Meaning
1	Reserved
10	Reserved
100	Reserved
1000 Read Only	1 = Alarm "Overload" 0 = Normal state.
10000	1 = Regulation ON (ON Comm and acknowl edge) 0 = Regulation OFF
100000 Read Only	1 = Alarm "CutOut" (Breaker) 0 = Normal state.
1000000 Read Only	1 = Alarm "OverHeat" 0 = Normal state
10000000 Read Only	1 = Alarm "SectorDefault" 0 = Normal state.

Byte 2 and 3 : P not Ok byte content :

1 bit per lamp. The bit is set to 1 when the OVR10 can not apply the required power to the given lamp. 4 bits reserved.

V1	V2	...	V12	Rs1	...	Rs4
bit0	bit1		11	12		15

Byte 4 and 5 : BL Dead Lamp byte content :

1 bit per lamp. The bit is set to 1 when the OVR1010 detects a load fault

L1	L2	...	L12	Rs1	...	Rs4
bit0	bit1		11	12		15

Byte 6-9 : Sqr(Vrms) byte content Square V(rms) read by the OVR10

Output datagram (M -> S) (37 Word)

WORD 1 . Byte 0 : Command byte content :

bit	Meaning
1	<i>Reserved</i>
10	<i>Reserved</i>
100	<i>Reserved</i>
1000 <i>Read Only</i>	Not used
10000	1 = Regulation ON 0 = Regulation OFF
100000 <i>Read Only)</i>	Not used
1000000 <i>Read Only</i>	Not used
10000000 <i>Read Only</i>	Not used

WORD 1. Byte 1 : NOT USED

WORD 2 – WORD 13 : Power expressed in Watts, to be applied to each channel.

WORD 14- 25 : Service voltage of the lamps

WORD 26-37 : Nominal power (W) of the lamps.

In version OVR_STD_SHORT, the words 14-37 are not used.

Summary : Basic steps to start the regulation (STD12 protocol) :

- Set the Service voltage for the loads.
- Set the nominal power for the loads.
- Set the desired power for the loads
- Start the regulation.
- Set the power for other lamps or modify the desired power.

Profibus DP: For Programs 20.X

The length of users parameters is 5 bytes but are not used.

No extended diagnostic is used.

The length of data exchange datagrams is :

- 6 bytes IN (Slave to Master)
- 11 bytes OUT (Master to Slave)

Protocol description and datagram format:

Input Datagram (S to M) (6 bytes)

Command	Reserved.	Vrm s		Dead Lamps	
0	1	2	3	4	5

Byte 0: Command byte content:

SCT_D	OVR10HT	C_OUT	ON/OFF	OVR10L	OUT_R	Reserved	
7	6	5	4	3	2	1	0

Bits	Meaning
OUT_R	1 = Notif. Sector Out of Range (Sector < 360Vrms) 0 = Normal state.
OVR10L	1 = Alarm Overload 0 = Normal state.
ON/OFF	1 = Regulation ON 0 = Regulation OFF
C_OUT	1 = Alarm CutOut 0 = Normal state.
OVR1010HT	1 = Alarm OverHeat 0 = Normal state
SCT_D	1 = Alarm SectorDefault 0 = Normal state.

Byte 1: reserved:

This byte is not used.

Byte 2-3: Vrms byte content:

The supply voltage measured by the OVR10.

Byte 4 and 5: Dead Lamps bytes content:

1 bit per lamp. The bit is turned to 1 when the OVR10 detects a load fault.

L8	L7	L6	L5	L4	L3	L2	L1	Reserved						L10	L9
15	14	13	12	11	10	9	8	7	6	5	4	3	2	1	0
Byte4								Byte5							

Output datagram (M to S) (11 bytes)

Cmd.	L1	L2	L3	L4	L5	L6	L7	L8	L9	L10
0	1	2	3	4	5	6	7	8	9	10

Byte 0 : Command byte content :

Reserved			ON/OFF	Reserved			
7	6	5	4	3	2	1	0

Bits	Meaning
ON/OFF	1 = Regulation ON 0 = Regulation OFF

Byte 1-10: Settings in Percents, to be applied to each channel.

These values should not exceed 100%. If it does, the setting 100% is applied.

Summary: Basic steps to start the regulation:

- Set the desired power for the loads
- Start the regulation.

Leds Signification:

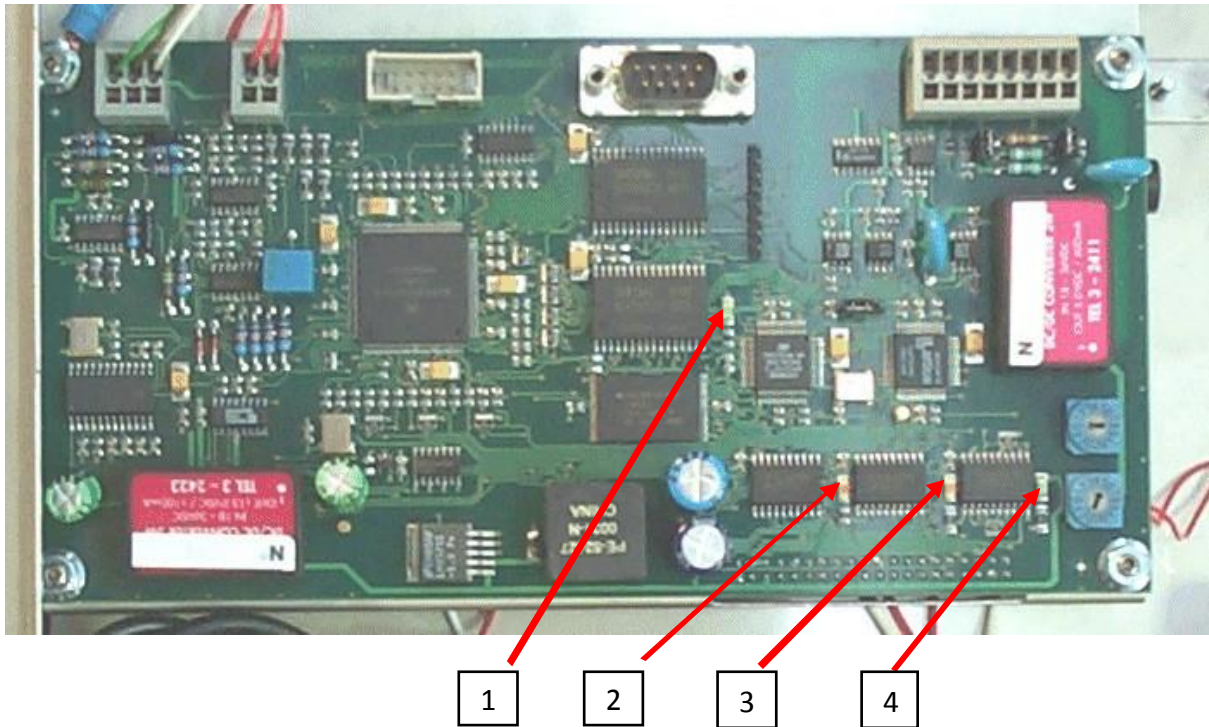

LED	ON	OFF
(1)	Profibus-DP connected	No datagram exchange
(2)	MPU running	MPU error (firmware)
(3)	400 VAC ON	400 VAC OFF
(4)	24 VDC on	24 VDC off

5.4 Setting the bus address

PROFIBUS-DP slave address.

A unique bus address must be set for each OVR10 connected to the Profibus DP on the machine. OVR10 modules address is configured using the two rotary switches (*sw1* & *sw2*) located on the bottom right corner of the MPU Board.

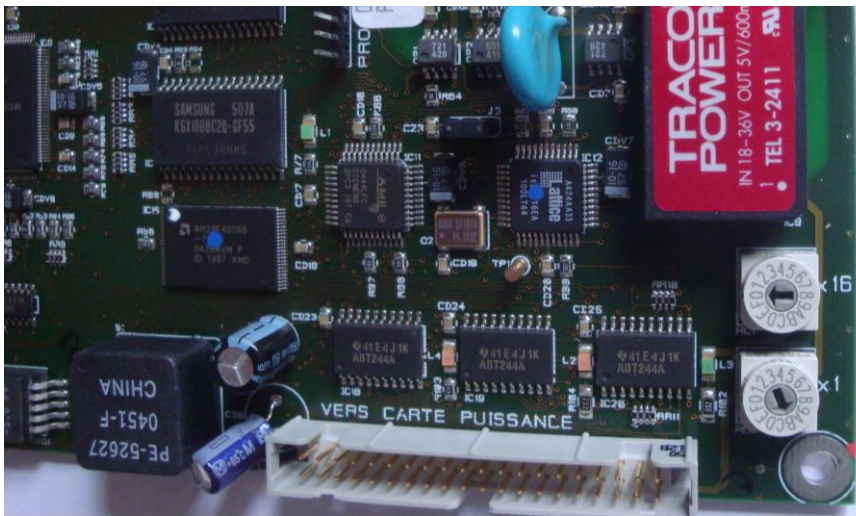

PROFIBUS_DP address is displayed as hexadecimal value:

$PFBaddr = SW2value \& SW1value$ (hex.)

Example:

$PFBaddr = 1 \& 5 = 15$ (hex.)

$PFBaddr = 21$ (dec.)

How to adjust the Profibus address on each OVR10.

Step1:

Read the address of the OVR10 on the Sidel's Technical manual of the machine. (for example 16).
Shut down the power supply of the machine (all leds are off on the MPU Board).
Adjust the address on both rotary switches on the MPU Board.

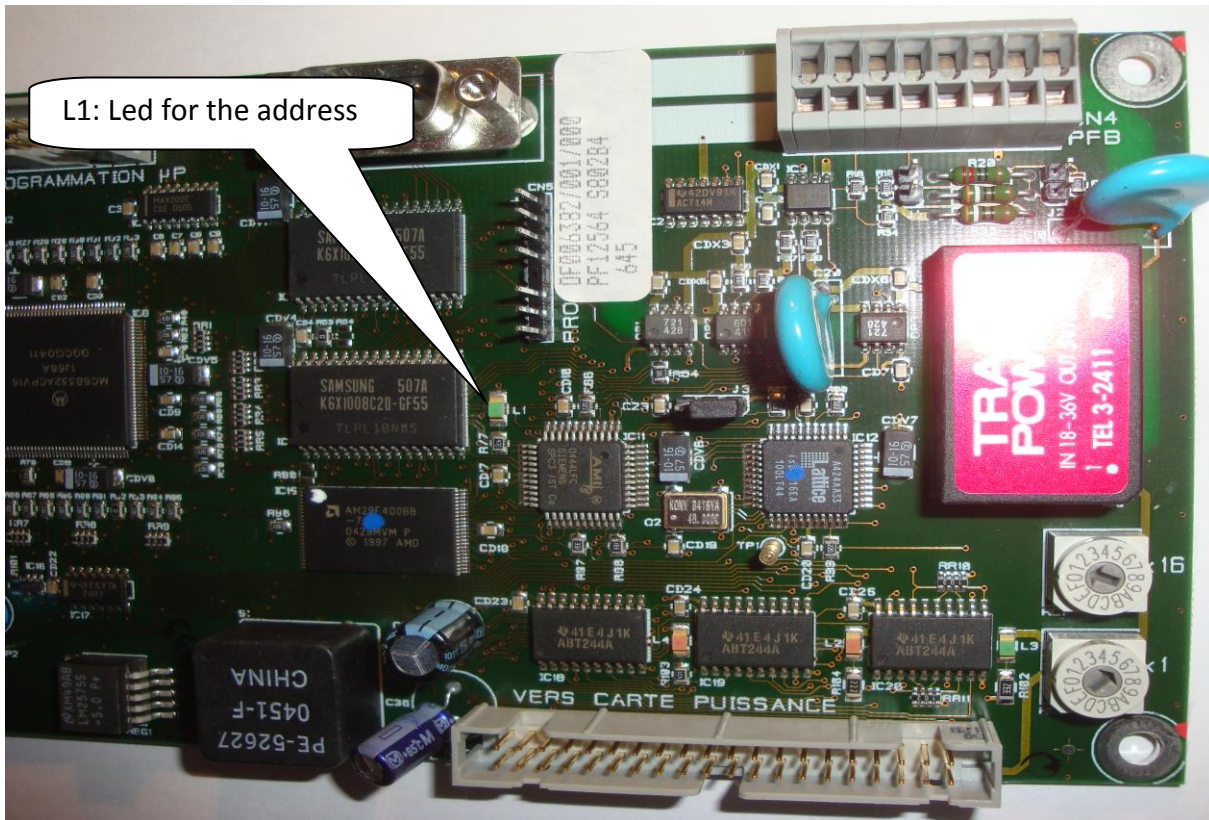

Step 2:

Turn on the power supply off the machine.
After a short time, the L1 led for address must be ON.

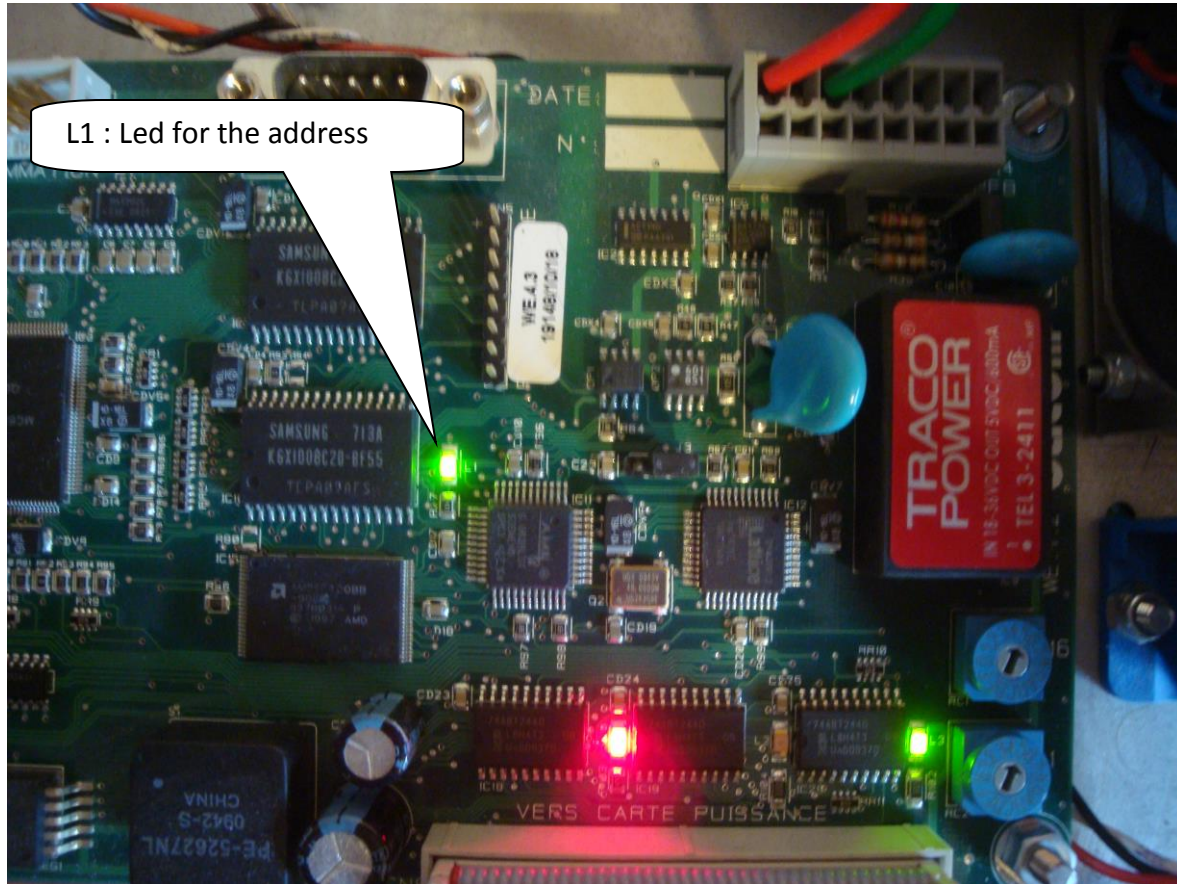

5.5 Profibus DP Bus terminator.

A bus terminator is required for terminating the Profibus DP.

If the OVR10 is located at the start or the end of a bus segment, the bus terminator must be connected on the connector X3 or X4.

These bus terminators are available by the company Harting (www.harting.com):

	Harting reference
Male plastic housing	09 12 006 2691
Male metal housing	09 12 006 2692
Female plastic housing	09 12 006 2791
Female metal housing	09 12 006 2792



Maintenance

6.1 Fuses replacement

When some lamps are broken in the oven of the machine, a short cut occurs.

Fuses installed on the Power electronic Board of the OVR10 protects the system up to 100KA for the breaking capacity.

These fuses are type 25A gG 10x38.

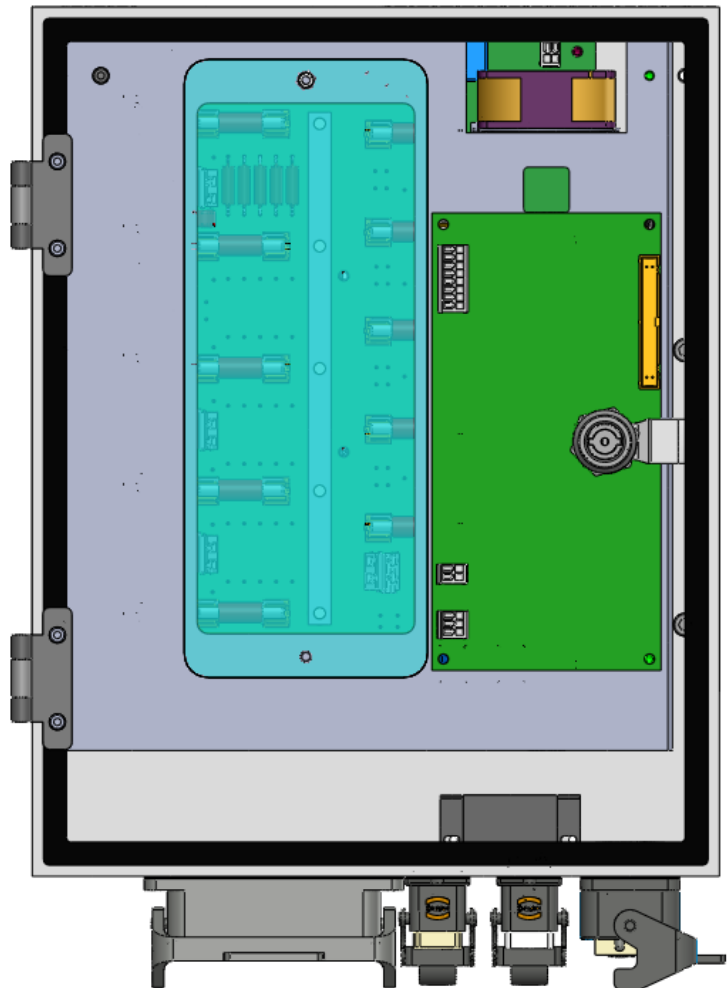

For any question, please contact Technoplan Engineering SA
at info@technoplan.info, or on the phone : +41 22 794 0084
